



PROGETTO IDEA STELLA

# BELPAESE

Design by ErvasBasilicoGirardi

BA  
THR  
OOM  
CO  
LLE  
CTIONS

# INDEX

STORIA - HISTORY - GESCHICHTE - HISTOIRE  
pag. 7

COLLEZIONE BAGNO  
BATHROOM COLLECTIONS  
BADMÖBELKOLLEKTION  
COLLECTIONS DE SALLE DE BAIN

BELPAESE  
pag. 8

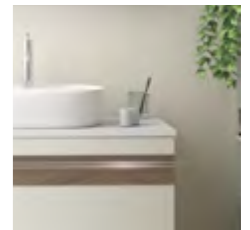

ELEMENTI, MISURE E FINITURE  
ELEMENTS, DIMENSIONS AND FINISHES  
BESTANDTEILE, MASSE UND AUSFÜHRUNGEN  
ÉLÉMENTS, DIMENSIONS ET FINITIONS  
pag. 69





## STORIA

Nata nel 1996 come una piccola realtà produttiva, con il trascorrere degli anni, Progetto Idea Stella ha subito una costante evoluzione che le ha permesso di essere presente ed apprezzata nel mercato nazionale ed internazionale.

Oggi la produzione dei mobili da bagno viene interamente realizzata nella propria struttura di 19.000 mq, caratterizzata da innovazione ed avanguardia tecnologica. Grande cura ed attenzione in tutto il processo produttivo: dalla selezione delle materie prime alla ricerca di forme e design, dalla qualità del prodotto al sistema di fabbricazione che richiama sia i valori artigianali, sia le tecniche industriali più performanti.

Da sempre creiamo, selezioniamo e produciamo mobili da bagno di qualità, in maniera responsabile, sempre al giusto prezzo. Questo è Progetto Idea Stella.

## HISTORY

Founded in 1996 as a small production company, over the years, Progetto Idea Stella has undergone a constant evolution that allowed to be present and to be appreciated in the domestic and international markets.

Today the production of bathroom furniture is made entirely in its own structure of 19,000 square meters, characterized by innovation and technological leadership. Great care and attention are paid throughout the production process: from the raw material selection to the research of shapes and designs. The quality of the product along with the manufacturing system draw their inspiration from both artisan competence and technological efficiency.

All along, we have created, selected and produced quality bathroom furniture with responsibility and at the best price. This is Progetto Idea Stella.

## GESCHICHTE

Progetto Idea Stella wurde 1996 als kleine Produktionsfirma gegründet; im Laufe der Jahre ist die Firma konstant gewachsen und wird heute am nationalen sowie am internationalen Markt geschätzt und anerkannt.

Heute werden die Badmöbel in unserer firmeneigenen, 19000 Quadratmeter umfassenden Anlage produziert, die durch innovative Technologie hervorsteicht. Große Sorgfalt und Aufmerksamkeit während des gesamten Produktionsprozesses: von der Auswahl der Rohmaterialien zur Forschung neuer Modelle und Design, von der Produktqualität zum Fertigungssystem, die die Werte des Handwerkes und die leistungsstärkste Industrietechnik verbinden.

Seit jeher entwickeln und produzieren wir Qualitätsbadmöbel auf verantwortungsvolle Weise, immer zum besten Preis. Das ist Progetto Idea Stella.

## HISTOIRE

Fondée en 1996 comme une petite société de production, pendant les années, Progetto Idea Stella a connu une évolution constante qui il a permis d'être présente et appréciée sur les marchés national et international.

Aujourd'hui la production de meubles salle de bain est entièrement réalisée dans sa propre structure de 19.000 mètres carrés, caractérisés par l'innovation et l'avant-garde technologique. Un grand soin et l'attention tout au long du processus de production: de la sélection des matières premières à la recherche de formes et de design, de la qualité du produit au système de fabrication qui fait appel aux valeurs artisanales mais aussi bien aux techniques industrielles les plus performantes.

Depuis toujours nous développons, sélectionnons et créons des meubles salle de bain de qualité, de manière responsable, toujours au juste prix. Tout cela est Progetto Idea Stella.



# BELPAESE

design by ErvasBasilicoGirardi

Funzionale, dinamica ed essenziale. La collezione BELPAESE esprime il suo carattere con elementi contenitivi che rispondono alle quotidiane esigenze di estetica e praticità. Gli elementi a specchio impreziosiscono e donano luce ed eleganza alle figure compositive.

Functional, dynamic and essential. The collection BELPAESE expresses its character through storage elements, that meet the daily needs of aesthetics and practicality. The mirror elements embellish and give light and elegance to the whole composition.

Funktional, dynamisch und essentiell. Die Kollektion BELPAESE zeigt seinen Charakter durch geräumigen Bestandteile, die den täglichen Bedarf erfüllen, ohne auf die Aesthetik zu verzichten. Die Spiegelemente verschönen und geben der ganzen Zusammenstellung Licht und Eleganz.

Fonctionnel, dynamique et essentiel. La collection BELPAESE exprime son caractère avec unité de stockage qui répondent aux besoins quotidiens des esthétique et praticité. Les éléments miroirs ils embellissent et donnent de la lumière et de l'élégance aux figures composition.





Base bianco "crema" ad un cassetto con lavabo  
in mineralmarmo. Specchio contenitore  
a giorno con elementi obliqui riflettenti.  
Elementi a giorno salvaspazio.

One drawer base white "crema"  
with mineral-marble washbasin.  
Open mirror cabinet with reflective oblique  
elements. Spacesaving open elements.

Unterschrank weiss "crema" mit einer Schublade  
und einem Mineralmarmor-Waschbecken. Offener  
Spiegelschrank mit schrägen reflektierenden  
Elementen. Platzsparende offene Schränke.

Base blanc "crema" à un tiroir avec,  
vasque en marbre moulé Armoire de toilette  
ouverte avec éléments obliques réfléchissants  
Compartiments ouverts peu encombrants.

cod. 10801





Composizione bianco opaco con specchio inciso modello Grace. Colonna sospesa con anta e vani a giorno.  
 Composition white matt with engraved mirror, model Grace. Hanging column with door and open shelves.  
 Komposition weiss matt mit graviertem Spiegel, Modell Grace. Hängender Hochschrank mit Tür und offenen Fächern.  
 Composition blanc mat avec miroir gravé, modèle Grace. Colonne suspendue avec porte et étagères ouvertes.

cod. 10802



Fascia frontale a specchio con incisione opaca  
 Lavabo in minerlmarmo modello Malibù.

Front mirror band with matt engraving  
 Mineral-marble washbasin, model Malibù.

Frontspiegelband mit matter Gravur  
 Mineralmarmor-Waschbecken, Modell Malibù.

Bande de rétroviseur avant avec gravure mate  
 Vasque en marbre Moulè, modèle Malibù.





Top BIANCO NORTE. Lavabo in appoggio in ceramica.  
 Top WHITE NORTE. Countertop ceramic-washbasin.  
 Platte WEISSE NORTE. Keramik Aufsatzwaschbecken.  
 Plan BLANC NORTE. Vasque à poser en céramique.

Finitura BIANCO CREMA OPACO Lavabo in appoggio in ceramica  
 Specchio contenitore a giorno con elementi obliqui riflettenti.

Matt finishing, BIANCO CREMA Countertop ceramic-washbasin  
 Open mirror cabinet with reflective oblique elements.

Matte Oberfläche BIANCO CREMA Keramik Aufsatzwaschbecken  
 Offener Spiegelschrank mit schrägen Spiegelementen.

Finition BIANCO CREMA opaque Vasque à poser en céramique  
 Armoire de toilette ouverte avec éléments obliques réfléchissants.

cod. 10803





Finitura TABACCO Lavabo  
in appoggio in ceramica  
Specchiera, modello Dama.

TABACCO finishing  
Countertop ceramic-washbasin  
Mirror, model Dama.

Oberfläche TABACCO  
Keramik Aufsatzwaschbecken  
Spiegel, Modell Dama.

Finition TABACCO.  
Vasque à poser en céramique.  
Miroir, modèle Dama.

cod. 10804







Lavabo consolle in mineralmarmo.  
Mineral-marble washbasin.  
Gussmarmor-Waschbecken.  
Vasque en marbre moulé.

Finitura HONEY. Lavabo mineralmarmo.  
Specchio con illuminazione led. Colonne con anta e vani a giorno.

HONEY finishing. Mineral-marble washbasin.  
Mirror with led lighting. Hanging column with door and open shelves.

Oberfläche HONEY Gussmarmor-Waschbecken. Spiegel mit LED-Beleuchtung.  
Hängender Hochschrank mit Tür und offenen Fächern.

HONEY finition. Vasque en marbre moulé. Miroir avec éclairage led.  
Colonnes avec porte et compartiments ouverts.

cod. 10805



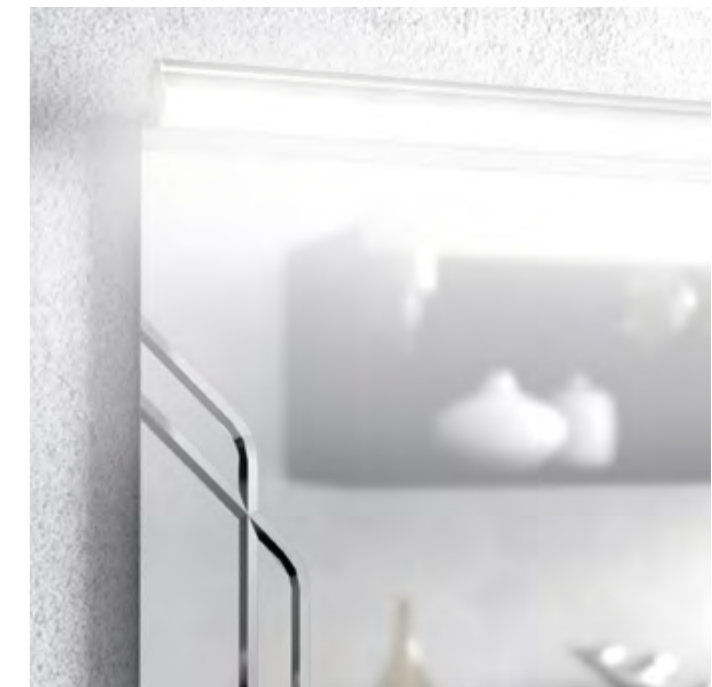

Specchio inciso, modello GRACE.  
Engraved mirror, model GRACE.  
Gravierter Spiegel, Modell GRACE.  
Miroir gravé, modèle GRACE.

Fascia frontale vetro fumè con incisione opaca.  
Smoky front mirror band with matt engraving.  
Getönte Frontspiegelband mit matter Gravur.  
Bande avant en verre fumé avec gravure mate.

Nero Opaco. Lavabo ELITE in ceramica. Specchio, modello GRACE.  
Matt black. Ceramic washbasin, ELITE. Mirror, model GRACE.  
Matt schwarz. Keramikwaschbecken ELITE. Spiegel, Modell GRACE.  
Noir mat. Vasque en céramique ELITE. Miroir, modèle GRACE.

cod. 10806





Base e colonna in finitura  
TABACCO. Pensili a giorno  
grigio antracite.  
Lavabo in mineralmarmo.  
Specchiera, modello DAMA.

Base and column in TABACCO  
finishing. Anthracite gray open  
hanging cabinets.  
Mineral-marble washbasin.  
Mirror, model DAMA.

Oberfläche vom Unterschrank  
und Hochschrank TABACCO.  
Offene Hängeschränke  
Anthrazitgrau  
Gussmarmor-Waschbecken  
Spiegel, Modell DAMA.

Base et colonne en finition  
TABACCO. Éléments hauts  
ouverts gris anthracite.  
Vasque en marbre moulé  
Miroir, modèle DAMA.

cod. 10807





Finitura NATURAL GRAY  
Lavabo in appoggio in  
ceramica Specchiera,  
modello GRACE.

NATURAL GRAY finishing  
Countertop ceramic  
washbasin Mirror,  
model GRACE.

Oberfläche NATURAL  
GRAY Keramik  
Aufsatz-Wasc becken  
Spiegel, Modell GRACE.

Finition NATURAL GRAY  
Vasque à poser en  
céramique Miroir,  
modèle GRACE.

cod. 10808





Lavabo mineralmarmo, modello Malibù 120. Mineral-marble Washbasin, model Malibù 120.  
Gussmarmor-Waschbecken, Modell Malibù 120. Vasque en marbre moulé, modèle Malibù 120.



Lavabo mineralmarmo, modello Lila 90. Mineral-marble washbasin, model Lila 90.  
Gussmarmor-Waschbecken, Modell Lila 90. Vasque en marbre moulé, modèle Lila 90.



Lavabo in ceramica, modello Elite 120. Ceramic-washbasin, model Elite 120.  
Keramikwaschbecken, Modell Elite 120. Vasque en céramique, modèle Elite 120.



Lavabo mineralmarmo doppia vasca, modello Lila 120. Double mineral-marble washbasin, model Lila 120.  
Gussmarmor-Doppelwaschbecken, Modell Lila 120. Vasque double en marbre moulé, modèle Lila 120.



ELEMENTI - MISURE - FINITURE  
ELEMENTS, DIMENSIONS AND FINISHES  
BESTANDTEILE, MASSE UND AUSFÜHRUNGEN  
ÉLÉMENTS, DIMENSIONS ET FINITIONS



# BELPAESE

BC1 pag.10 cod. 10801

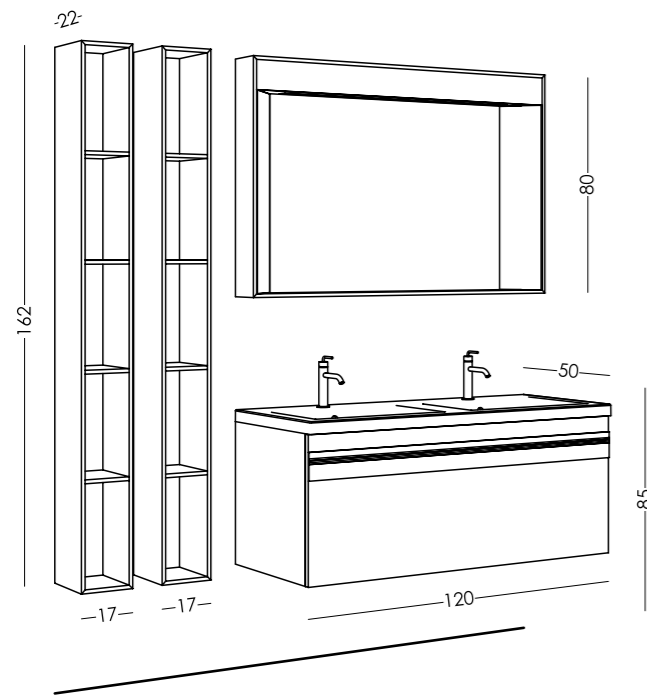

COD.	DESCRIZIONE - DESCRIPTION BEZEICHNUNG - DESCRIPTION	N.
09578	Specchio "Trittico" con elementi obliqui, fumé. Luce led calda. Mirror "Trittico" with smoky oblique elements. Warm Led lighting. Spiegel "Trittico" mit schrägen getönten Elementen. Warme Led. Beleuchtung. Miroir "Trittico" avec éléments obliques. Éclairage LED chaleureux.	1
00898	Lavabo doppia vasca in mineralmarmo "Lila" 120. Double mineral-marble washbasin "Lila" 120. Doppelmineralmarmor-Waschbecken "Lila" 120. Double vasque en marbre moulé "Lila" 120.	1
10819	Base lavabo con 1 cassettone + cassetto interno. Bianco opaco con fascia in cristallo fumé. One drawer base with internal drawer. Smoky front mirror band with matt engraving. Unterschrank mit einer Schublade und einer internen Schublade. Weiss matt, mit getönten Frontspiegelband und matter Gravur. Caisson 1 tiroir avec tiroir intérieur. Blanc mat. Bande avant en verre fumé avec gravure mate.	1
10843	Colonna a giorno bianco opaco. Hanging open columns, white matt. Hängende offene Hochschränke, weiss matt. Colonnes ouvertes suspendues, blanc mat.	2

BC3 pag.15 cod. 10803

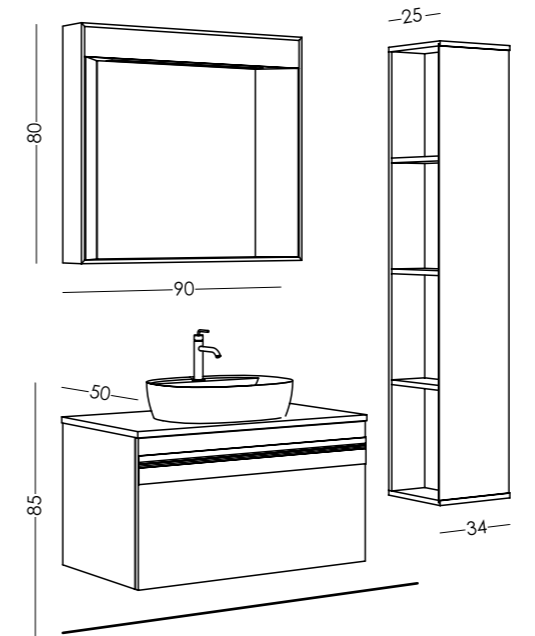

COD.	DESCRIZIONE - DESCRIPTION BEZEICHNUNG - DESCRIPTION	N.
09548	Specchio "Trittico" con elementi obliqui bronzo. Luce led calda. Mirror "Trittico" with bronze oblique elements. Warm Led lighting. Spiegel "Trittico" mit bronzenen schrägen Elementen. Warme Led Beleuchtung. Miroir Trittico" avec éléments obliques. Éclairage LED chaleureux.	1
13773	Lavabo d'appoggio in ceramica "Fino 50". Countertop ceramic-washbasin "Fino 50". Keramik Aufsatz-Waschbecken "Fino 50". Vasque à poser en céramique "Fino 50".	1
06947	Top Blanco Norte, bianco opaco. Top Blanco Norte, white matt. Platte Blanco Norte, weiss matt. Plan Blanco Norte, blanc mat.	1
10816	Base lavabo con 1 cassettone + cassetto interno. Bianco Crema opaco con fascia in cristallo bronzo. One drawer base with internal drawer. Bronze front mirror band with Crema matt engraving. Unterschrank mit einer Schublade und einer internen Schublade. Weiss Crema matt, mit bronzenem Frontspiegelband und matter Gravur. Caisson 1 tiroir avec tiroir intérieur. Blanc Crema mat Bande avant en verre fumé avec gravure mate.	1
10833	Colonna con frontale in vetro bronzo e truttura interna laccata bianca Crema opaca. Column with bronze glass front; structure white Crema matt painted. Hochschrank mit bronzenen Glasfront; Korpus weiss Crema matt lackiert. Colonne avec bande avant en verre fumé avec gravure mate, blanc Crema mat.	1

BC2 pag.12 cod. 10802

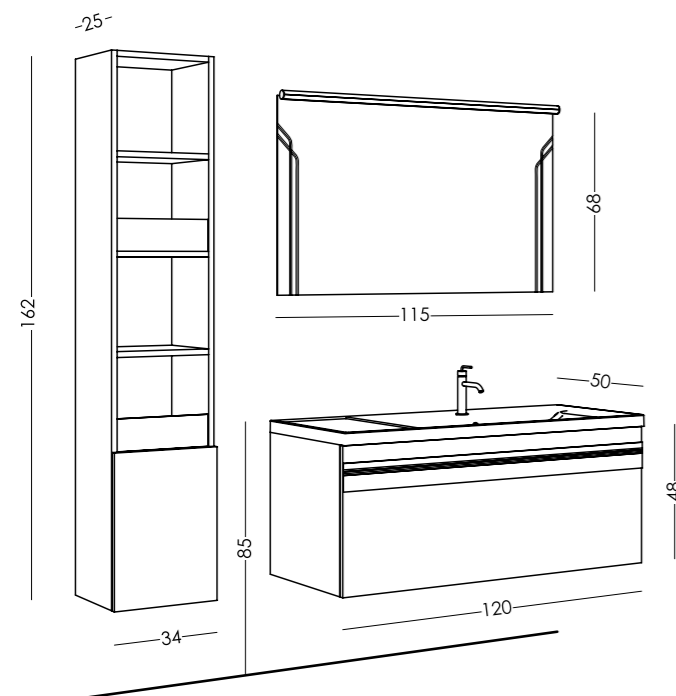

COD.	DESCRIZIONE - DESCRIPTION BEZEICHNUNG - DESCRIPTION	N.
09608	Specchio filo lucido "Grace" 115 con quattro incisioni laterali. Mirror "Grace" 115 with four lateral engravings. Spiegel "Grace" 115 mit vier Seitengravuren. Miroir "Grace" 115 avec quatre gravures latérales.	1
09400	Profilo cromato LED 115. LED chrom profile 115. Chromprofil mit Led Beleuchtung 115. Profil chromé avec éclairage LED 115.	1
09419	Lavabo in mineralmarmo "Malibù". Mineral-marble washbasin "Malibù". Gussmarmor-Waschbecken mit Seitenablage "Malibù". Vasque en marbre moulé "Malibù".	1
10819	Base lavabo con 1 cassettone + cassetto interno. Bianco opaco con fascia in cristallo fumé. One drawer base with internal drawer. Smoky front mirror band with matt engraving. Unterschrank mit einer Schublade und einer internen Schublade. Weiss matt, mit getönten Frontspiegelband und matter Gravur. Caisson 1 tiroir avec tiroir intérieur. Finition blanc mat avec bande avant en verre fumé avec gravure mate.	1
10838	Colonna sospesa con antina e vani a giorno. Bianco opaco. Hanging column, with door and open shelves. White matt. Hängender Hochschrank mit Tür und offenen Flächen. Weiss matt. Colonne suspendue, avec une porte et étagères ouvertes. Blanc mat.	1

BC4 pag.16 cod. 10804

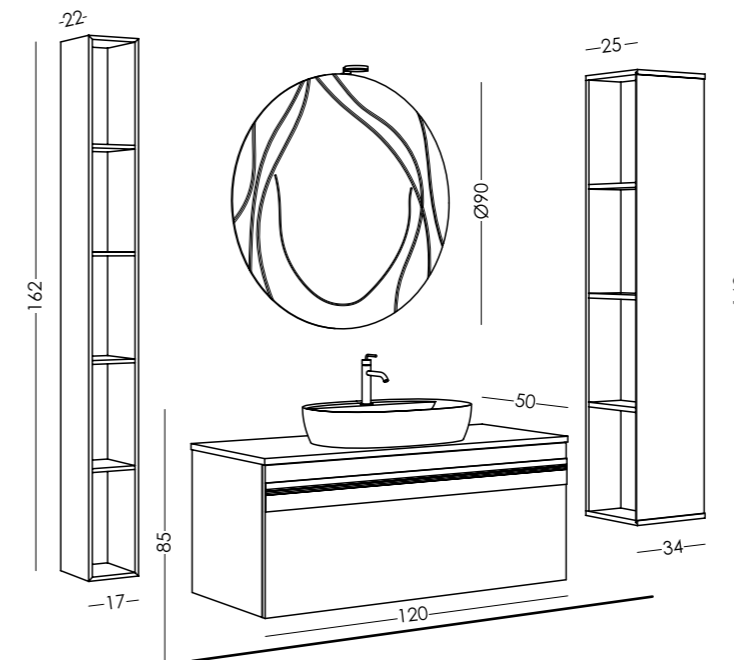

COD.	DESCRIZIONE - DESCRIPTION BEZEICHNUNG - DESCRIPTION	N.
09603	Specchio filo lucido "Dama" con incisioni volto donna. Mirror "Dama" with woman face engravings. Spiegel "Dama" mit Damengesicht-Gravuren. Miroir "Dama" avec des gravures de visage de femme.	1
07602	Lampada Led "Gilda". Led Light "Gilda". Led Lampe "Gilda". Lampe à LED "Gilda".	1
13774	Lavabo d'appoggio in ceramica "Fino 60". Countertop ceramic-washbasin "Fino 60". Keramik Aufsatz-Waschbecken "Fino 60". Vasque à poser en céramique "Fino 60".	1
06948	Top Blanco Norte, bianco opaco 120x50. Top Blanco Norte, white matt 120x50. Platte Blanco Norte, weiss matt 120x50. Plan Blanco Norte, blanc mat 120x50.	1
10818	Base lavabo con 1 cassettone + 1 cassetto interno. Finitura "Tabacco" e fascia in cristallo fumé. One drawer base with internal drawer. "Tabacco" finishing with smoky front mirror band. Unterschrank mit einer Schublade und einer internen Schublade. Ausführung "Tabacco" mit getönten Frontspiegelband. Caisson 1 tiroir avec tiroir intérieur "Tabacco" finition et bande avant en verre fumé avec gravure mate.	1
10832	Colonna con frontale in vetro fumé. Column with smoky glass front. Hochschrank mit getönten Glasfront. Colonne avec bande avant en verre fumé.	1
10843	Colonna a giorno "antracite". Hanging open column, "antracite". Hängender offener Hochschrank, "antracite". Colonne ouverte suspendue "antracite".	1



BC5 pag.18 cod. 10805

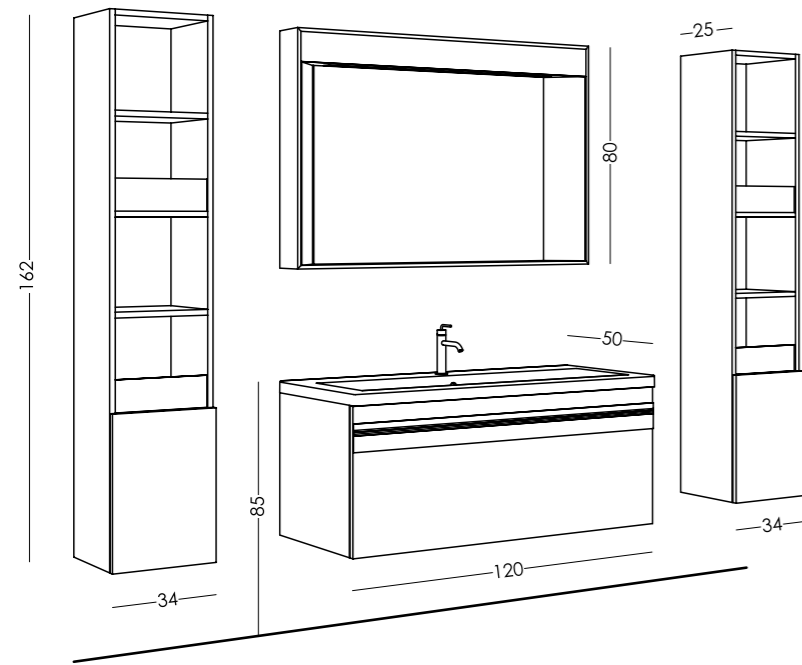

COD.	DESCRIZIONE - DESCRIPTION BEZEICHNUNG - DESCRIPTION	N.
09579	Specchio "Trittico" "beige grigio" con elementi obliqui, bronzo. Luce led calda. Mirror "Trittico" "beige grigio" with bronze oblique elements, Warm Led lighting. Spiegel "Trittico" "beige grigio" mit bronzenen schrägen Elementen. Warme Led Beleuchtung. Miroir "Trittico" "beige grigio" avec éléments obliques bronzo. Éclairage LED chaleureux.	1
00899	Lavabo in mineralmarmo "Lila" 120. Mineral-marble washbasin "Lila" 120. Gussmarmor-Waschbecken "Lila" 120. Vasque en marbre moulé "Lila" 120.	1
10818	Base lavabo con 1 cassettone + 1 cassetto interno. Finitura "Honey" e fascia in cristallo bronzo. One drawer base with internal drawer. "Honey" Finishing with bronze front mirror band. Unterschrank mit einer Schublade und einer internen Schublade. Ausführung "Honey" mit bronzenen Frontspiegelband. Caisson 1 tiroir avec tiroir intérieur Honey finition et bande avant en verre fumé avec gravure mate.	1
10837	Colonna sospesa con antina e vani a giorno. Finitura "Honey". Hanging column, with door and open shelves. Finishing "Honey". Hängender Hochschrank mit Tür und offenen Flächen. "Honey" Ausführung. Colonne suspendue avec une porte et étagères ouvertes, finition "Honey".	2

BC7 pag.22 cod. 10807

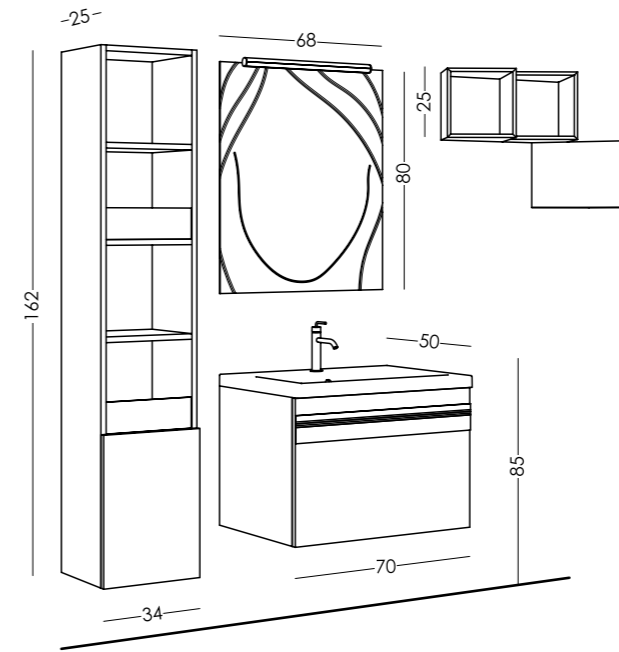

COD.	DESCRIZIONE - DESCRIPTION BEZEICHNUNG - DESCRIPTION	N.
09602	Specchio "Dama" con incisioni volto donna. Mirror "Dama" with woman face engravings. Spiegel "Dama" mit Damengesicht-Gravuren. Miroir "Dama" avec des gravures de visage de femme.	1
09396	Profilo cromato LED 52. LED chrom profile 52. Chromprofil mit Led Beleuchtung 52. Profil chromé avec éclairage LED 52.	1
00896	Lavabo in mineralmarmo "Lila 70". Mineral-marble washbasin "Lila 70". Gussmarmor-Waschbecken "Lila 70". Vasque en marbre moulé "Lila 70".	1
10812	Base lavabo con 1 cassettone + 1 cassetto interno. Finitura "Tabacco" e fascia in cristallo fumé. One drawer base with internal drawer. "Tabacco" with smoky front mirror band. Unterschrank mit einer Schublade und einer internen Schublade. Ausführung "Tabacco" mit getönten Frontspiegelband. Caisson 1 tiroir avec tiroir intérieur. Finition Tabacco" avec bande avant en verre fumé avec gravure mate.	2
10837	Colonna sospesa con antina e vani a giorno. Finitura "Tabacco". Hanging column, with door and open shelves. Finishing "Tabacco". Hängender Hochschrank mit Tür und offenen Flächen. "Tabacco" Ausführung. Colonne suspendue avec une porte et étagères ouvertes. Finition "Tabacco".	1
10851	Pensili a giorno quadrati, grigio opaco. Hanging square open cabinets, grey matt. Offene viereckige Hängeschränke, grau matt. Meubles haut ouvertes gris mat.	3

BC6 pag.20 cod. 10806

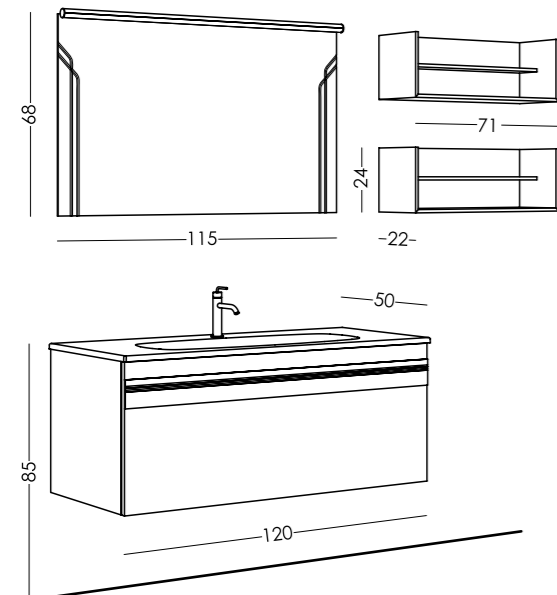

COD.	DESCRIZIONE - DESCRIPTION BEZEICHNUNG - DESCRIPTION	N.
09608	Specchio filo lucido "Grace" 115 con quattro incisioni laterali. Mirror "Grace" 115 with four lateral engravings. Spiegel "Grace" 115 mit vier Seitengravuren. Miroir "Grace" 115 avec quatre gravures latérales.	1
09400	Profilo cromato LED 115. LED chrom profile 115. Chromprofil mit Led Beleuchtung 115. Profil chromé avec éclairage LED 115.	1
10511	Lavabo in ceramica "Elite" 120. Ceramic-washbasin "Elite" 120. Gussmarmor-Waschbecken "Elite" 120. Vasque en céramique "Elite" 120.	1
10819	Base lavabo con 1 cassettone + 1 cassetto interno. Nero opaco e fascia in cristallo fumé. One drawer base with internal drawer. Black matt with smoky front mirror band. Unterschrank mit einer Schublade und einer internen Schublade. Schwarz matt mit getönten Frontspiegelband. Caisson 1 tiroir avec tiroir intérieur. Finition Noir mat avec bande avant en verre fumé avec gravure mate.	1
10848	Pensili a giorno laccati nero opaco. Hanging open cabinets, black matt. Offene Hängeschränke, schwarz matt. Meubles haut suspendues ouvertes, noir mat.	2

BC8 pag.24 cod. 10808

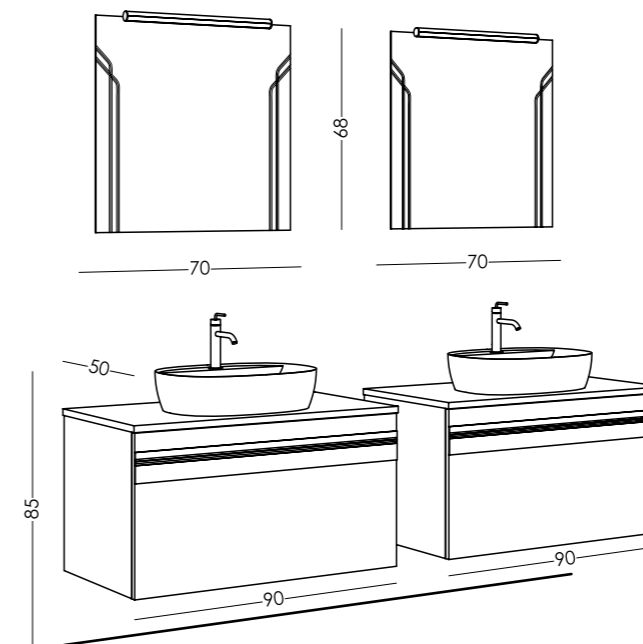

COD.	DESCRIZIONE - DESCRIPTION BEZEICHNUNG - DESCRIPTION	N.
09605	Specchio "Grace" 70 con quattro incisioni laterali. Mirror "Grace" 70 with four lateral engravings. Spiegel "Grace" 70 mit vier Seitengravuren. Miroir "Grace" 70 avec quatre gravures latérales.	2
09396	Profilo cromato LED 52. LED chrom profile 52. Chromprofil mit Led Beleuchtung 52. Profil chromé avec éclairage LED 52.	2
13773	Lavabo d'appoggio in ceramica "Fino 50". Countertop ceramic-washbasin "Fino 50". Keramik Aufsatz-Waschbecken "Fino 50". Vasque à poser en céramique "Fino 50".	2
06947	Top Blanco Norte, bianco opaco 90x50. Top Blanco Norte, white matt 90x50. Platte Blanco Norte, weiss matt 90x50. Plan Blanco Norte, blanc mat 90x50.	2
10815	Base lavabo con 1 cassettone + 1 cassetto interno. Finitura "Natural Grey" e fascia in cristallo fumé. One drawer base with internal drawer. "Natural Grey" with smoky front mirror band. Unterschrank mit einer Schublade und einer internen Schublade. "Natural Grey" mit getönten Frontspiegelband. Caisson 1 tiroir avec tiroir intérieur. Finition "Natural Grey" avec bande avant en verre fumé avec gravure mate.	2



**LAVABI INTEGRATI / WASHBASIN / WASCHECKEN / VASQUE**

Elite

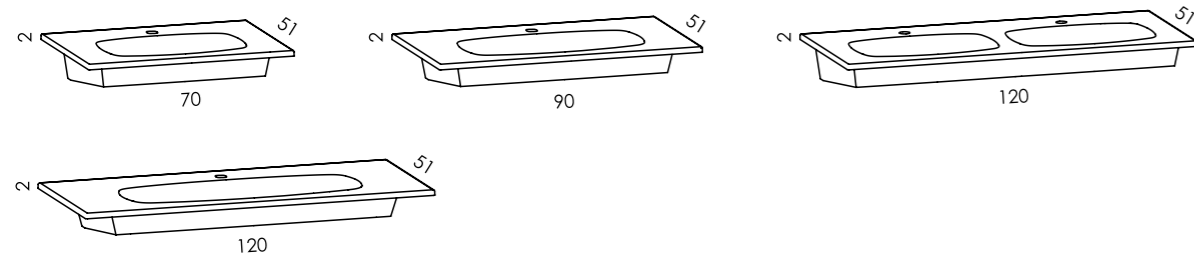

Lila

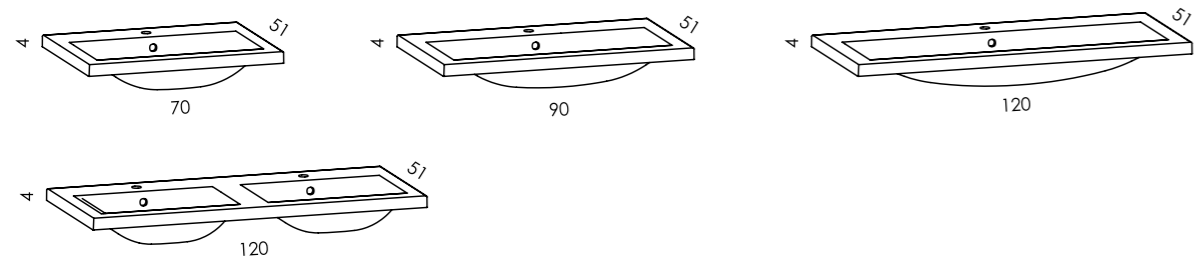

Malibù

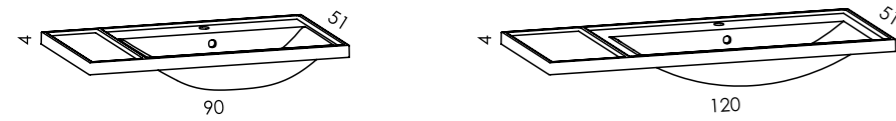

**LAVABI APPOGGIO/ CONTERTOP WASHBASIN / AUFSATZ-WASCHECKEN / VASQUE À POSER**

Fino

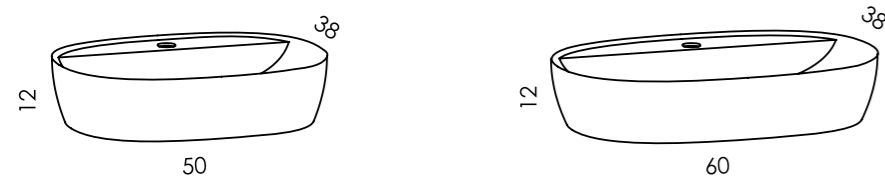

SQUARE 50

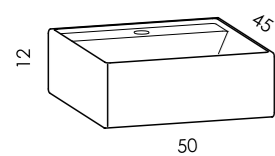

**TOP / TOP / PLATTE / PLAN**

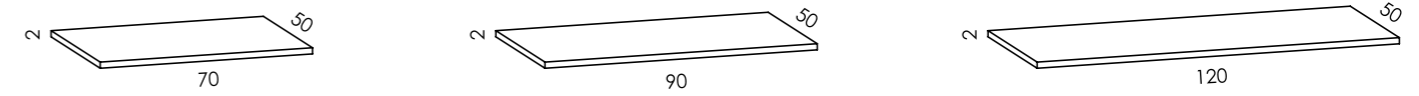

**BASI LAVABO / BASE / UNTERSCHRANK / BASE**

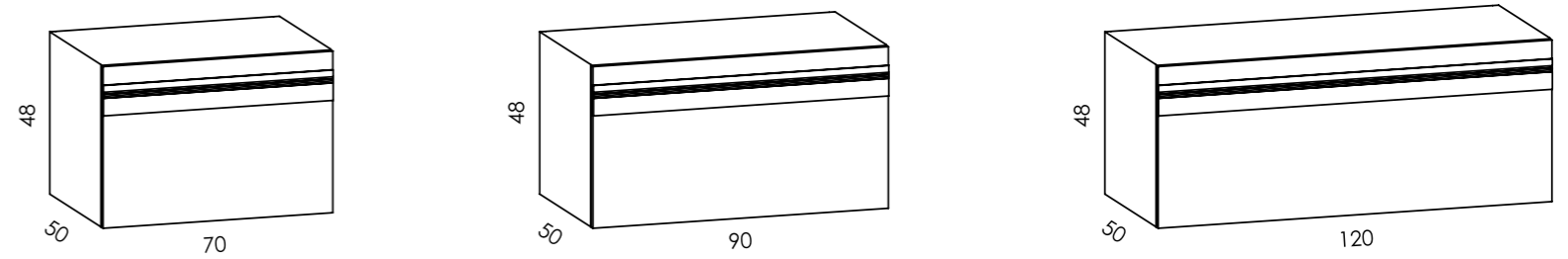

**COLONNE SOSPESSE / HANGING COLOUMN / HÄNGENDER HOCHSCHRANK / COLONNE SUSPENDUE**

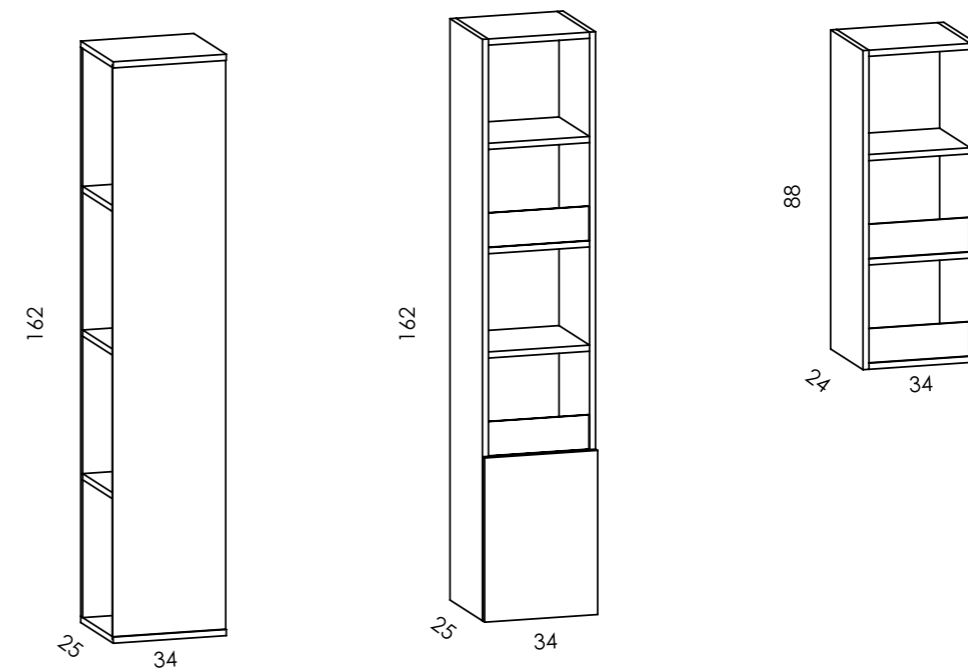



**PENSILI / HANGING CABINET / HÄNGESCHRANK / MEUBLE HAUT**

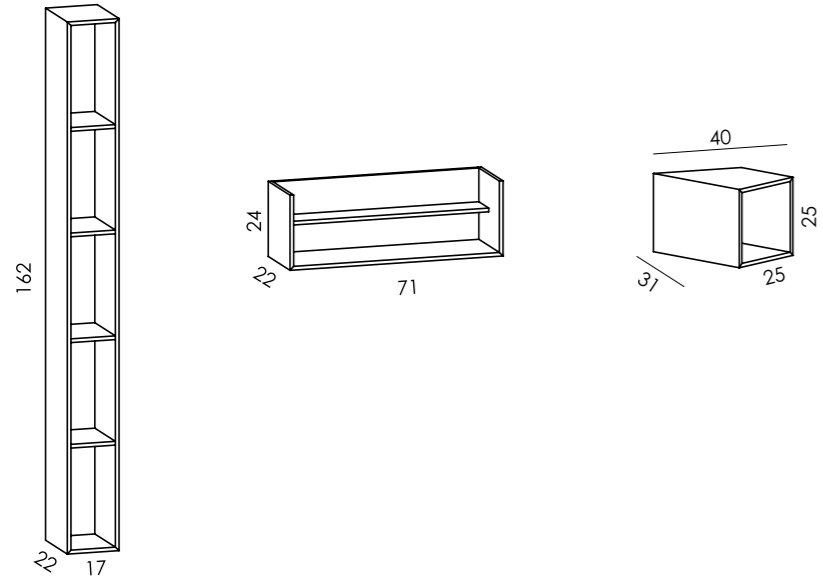

**SPECCHI / MIRRORS / SPIEGEL / MIROIR**

Trittico

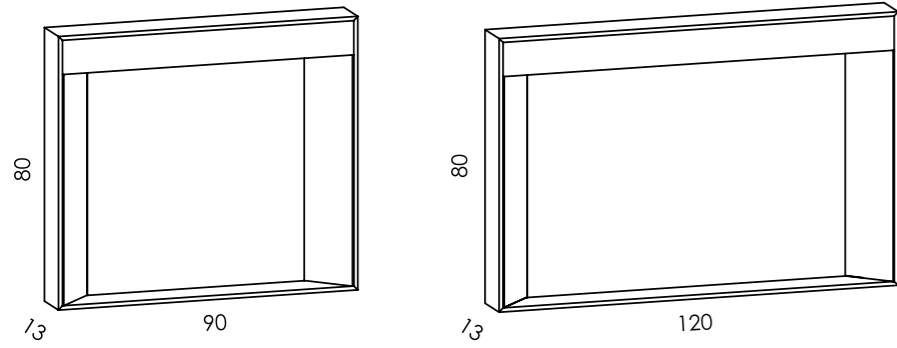

Dama

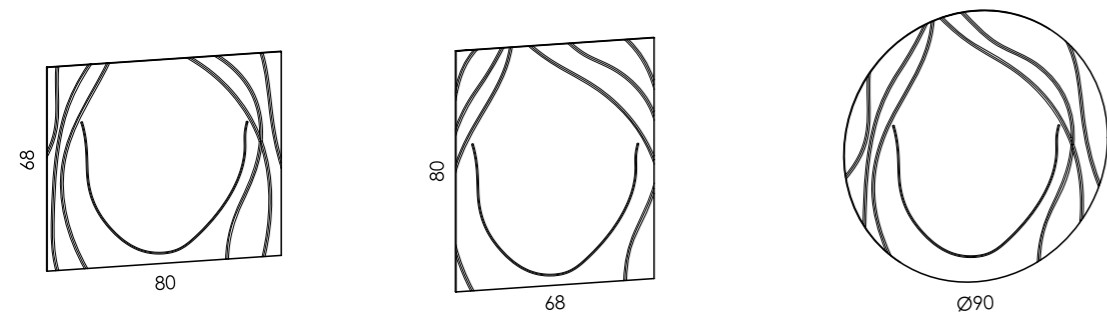

Grace

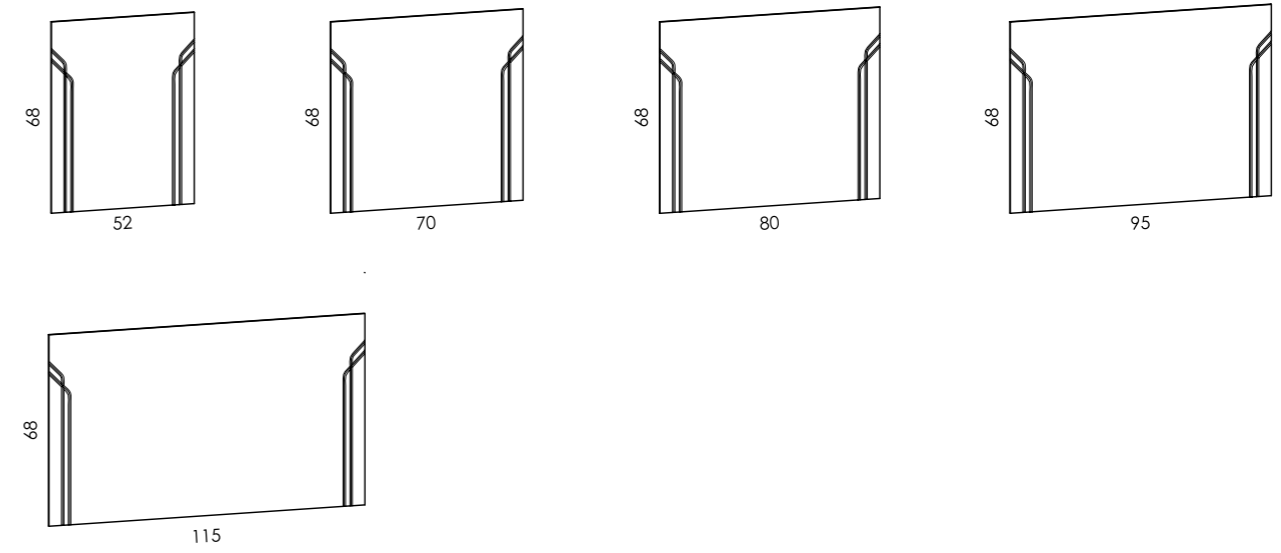

**LAMPADE / LAMP / LAMPE / LAMPE**

Profili cromo

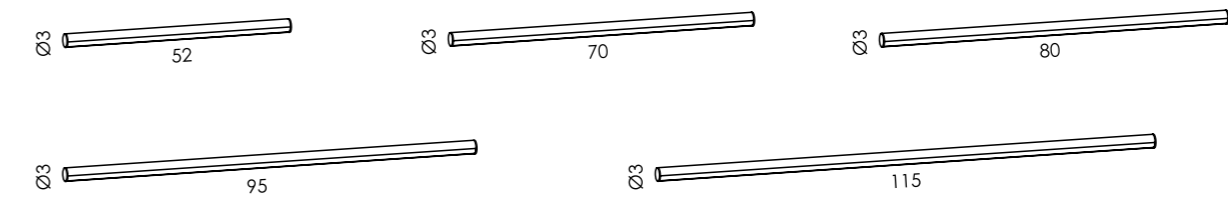

Venere

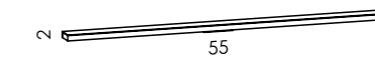

Smart

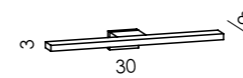

Gilda

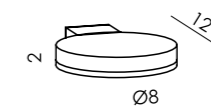

Keras

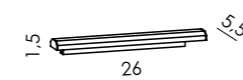



**LACCATO / LACQUERED / LAKIERT / LAQUÉ**



**LEGNO NOBILITATO/ MELAMINE WOOD / HOLZ DEKOR / BOIS MÉLAMINÉ**

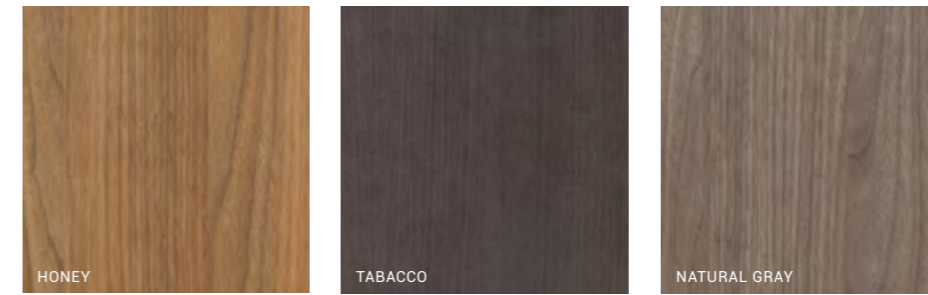

**VETRO / GLASS / GLAS / VERRE**

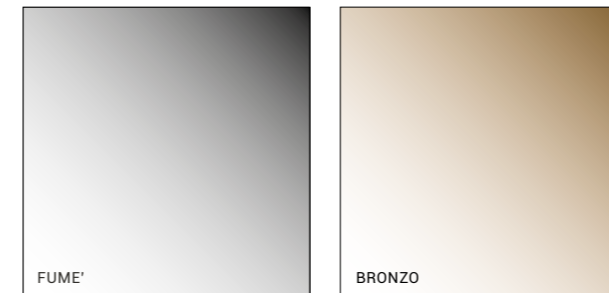

**PIANI LAVABO / TOP / PLATTE / PLAN**

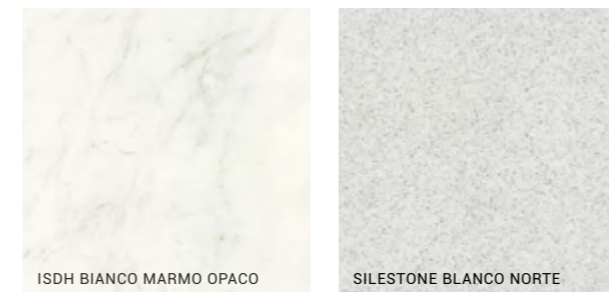

Per la reale tonalità, consultare la mazzetta RAL.  
 For the real shade, consult the RAL swatch book.  
 Den tatsächlichen Farbton entnehmen Sie bitte dem RAL-Musterbuch.  
 Pour la vraie teinte, consultez le nuancier RAL.

I colori e le finiture si intendono puramente indicativi.  
 The colors and finishes are purely indicative.  
 Die Farben und Oberflächen sind rein indikativ.  
 Les couleurs et finitions sont purement indicatives.



**Progetto Idea Stella**  
Via 81<sup>a</sup> strada 2  
63076 Centobuchi (AP) Italy  
T +39 0735 705242  
F +39 0735 705305  
[www.ideastella.com](http://www.ideastella.com)  
[webmaster@ideastella.com](mailto:webmaster@ideastella.com)



**art direction**  
ErvasBasilicoGirardi  
[www.ervasbasilicogirardi.it](http://www.ervasbasilicogirardi.it)

**COPYRIGHT PROGETTO IDEA STELLA srl**  
**ALL RIGHTS RESERVED**

Modifiche e migliorie ai prodotti potrebbero variare l'estetica delle soluzioni presentate.  
Products changes and improvements might vary the aesthetics of the shown solutions.  
Produktänderungen und -verbesserungen vorbehalten.  
Nous nous réservons d'apporter des modifications et améliorations à tous nos produits.  
Modificaciones y mejoras en el producto podrían variar la estética de las soluciones presentadas.



